

# VESTING TENTATIVE MAP

## No. 83858

FOR SUBDIVISION AND CONDOMINIUM PURPOSES

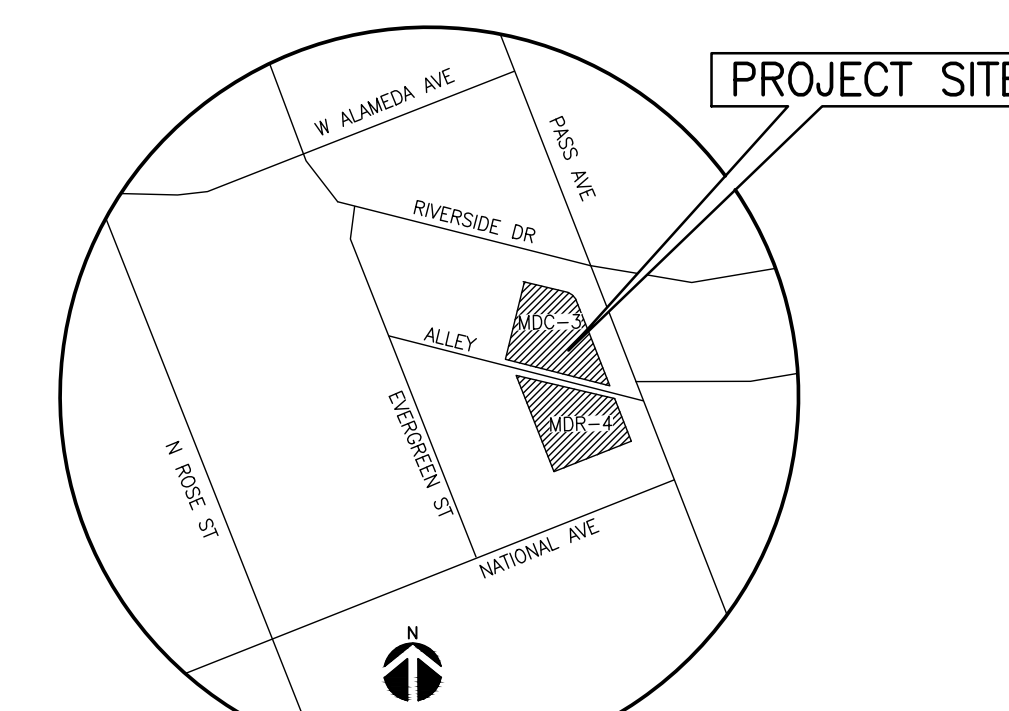

VICINITY MAP  
SCALE: 1"=300'



700 FLOWER ST., SUITE 2100  
LOS ANGELES, CA 90017  
P: 213.438.0001  
F: 213.268.5294  
www.kpff.com

OWNERS:

4100 RIVERSIDE LLC  
4100 RIVERSIDE DRIVE  
BURBANK, CA 91505  
ATTN:

SUBDIVIDER:

PLUS DEVELOPMENT GROUP, LLC  
4525 WILSHIRE BOULEVARD, SUITE 2100  
LOS ANGELES, CA 90010  
ATTN: KATIE MANGIN

LAND SURVEYOR:

KPFF CONSULTING ENGINEERS, INC  
700 S. FLOWER STREET, SUITE 2100  
LOS ANGELES, CA 90017  
CONTACT: CHRIS JONES, PLS  
(213) 418-0201

### LEGAL DESCRIPTION

(PER CHICAGO TITLE COMPANY ORDER No. 00147759-994-LT2-DB DATED MARCH 8, 2021)

THE LAND REFERRED TO HEREIN BELOW IS SITUATED IN THE CITY OF BURBANK, IN THE COUNTY OF LOS ANGELES, STATE OF CALIFORNIA, AND IS DESCRIBED AS FOLLOWS:

LOTS 166 AND 167 OF TRACT NO. 9517, IN THE CITY OF BURBANK, COUNTY OF LOS ANGELES, STATE OF CALIFORNIA, AS PER MAP RECORDED IN BOOK 134 PAGES 89 THROUGH 91 INCLUSIVE OF MAPS, IN THE OFFICE OF THE COUNTY RECORDER OF SAID COUNTY.

APN: 2485-008-034

### LEGAL DESCRIPTION

(PER FIRST AMERICAN TITLE COMPANY ORDER No. NCS-912048-LA2, DATED AUGUST 3, 2018)

THE LAND REFERRED TO HEREIN BELOW IS SITUATED IN THE CITY OF BURBANK, IN THE COUNTY OF LOS ANGELES, STATE OF CALIFORNIA, AND IS DESCRIBED AS FOLLOWS:

LOTS 166 AND 167, 173 AND 174 OF TRACT NO. 9517, IN THE CITY OF BURBANK, COUNTY OF LOS ANGELES, STATE OF CALIFORNIA, AS PER MAP RECORDED IN BOOK 134 PAGES 89 THROUGH 91 INCLUSIVE OF MAPS, IN THE OFFICE OF THE COUNTY RECORDER OF SAID COUNTY.

APN: 2485-008-034 AND 2485-008-032

### EXCEPTIONS

(PER CHICAGO TITLE COMPANY ORDER No. 00147759-994-LT2-DB DATED MARCH 8, 2021)

THERE ARE NO EASEMENTS OR APPARENT SURVEY MATTERS CONTAINED IN THIS TITLE REPORT.

### EXCEPTIONS

(PER FIRST AMERICAN TITLE COMPANY ORDER No. NCS-912048-LA2, DATED AUGUST 3, 2018)

4. AN EASEMENT FOR UTILITIES AND INCIDENTAL PURPOSES IN THE DOCUMENT RECORDED AS BOOK 6633 PAGE 56 OF OFFICIAL RECORDS.

(AFFECTS LOTS 173 AND 174)

### COMMENTS

SITE ADDRESS . . . . . 4100 RIVERSIDE DRIVE, BURBANK, CA 91505

APN NOS. . . . . 2485-008-034 AND 2485-008-032

BOUNDARY LINES . . . . . WERE ESTABLISHED FROM THE RECOVERED CITY, COUNTY AND/OR PRIVATE SURVEY MONUMENTS WHOSE CHARACTER AND SOURCE ARE SO NOTED ON THE SURVEY.

BASIS OF BEARINGS . . . . . THE BEARING OF N22°18'14"W ALONG THE CENTERLINE OF PASS AVENUE AS SHOWN ON THE MAP OF TRACT NO. 9517, AS RECORDED IN BOOK 134, PAGES 89 THROUGH 91 OF MAPS, IN THE OFFICE OF THE COUNTY RECORDER, WAS USED AS THE BASIS OF BEARINGS FOR THIS SURVEY.

LAND AREA . . . . . NORTH PARCEL:  
GROSS (PRE-DEDICATION) . . . . . 15,585 SQ. FT. OR 0.358 ACRES, MORE OR LESS.  
NET (POST-DEDICATION) . . . . . 15,284 SQ. FT. OR 0.351 ACRES, MORE OR LESS.  
SOUTH PARCEL:  
GROSS (PRE-DEDICATION) . . . . . 15,000 SQ. FT. OR 0.344 ACRES, MORE OR LESS.  
NET (POST-DEDICATION) . . . . . 14,997 SQ. FT. OR 0.344 ACRES, MORE OR LESS.

UTILITIES . . . . . ALL VISIBLE ABOVE-GROUND UTILITY FEATURES SHOWN ON THIS MAP WERE OBTAINED BY CONVENTIONAL MEANS. UNDERGROUND UTILITY LINES SHOWN HEREON PER ALTA/NSPS LAND TITLE SURVEY PREPARED BY HAHN AND ASSOCIATES, INC., DATED AUGUST 10, 2018, NO REPRESENTATION IS MADE AS TO THE COMPLETENESS OF SAID UTILITY INFORMATION AND ANY USER OF THIS INFORMATION SHOULD CONTACT THE UTILITY OR GOVERNMENT AGENCY DIRECTLY.

FLOOD INSURANCE RATE MAP . . . . . ZONE "X" AREAS DETERMINED TO BE WITHIN THE 0.2% ANNUAL CHANCE FLOOD HAZARD, AREAS OF 1% ANNUAL CHANCE FLOOD WITH AVERAGE DEPTH LESS THAN ONE FOOT OR WITH DRAINAGE AREAS OF LESS THAN ONE SQUARE MILE, FLOOD INSURANCE RATE MAP (FIRM) MAP PANEL MAP NO. 06037C1340F EFFECTIVE DATE SEPTEMBER 26, 2008.

ZONING INFORMATION . . . . . MDR-4 MEDIA DISTRICT R-4 AND MDC-3 MEDIA DISTRICT GENERAL BUSINESS (CURRENT & PROPOSED), INFORMATION FROM CITY OF BURBANK WEBSITE PULLED ON 2/17/2021.

# . . . . . INDICATES PRELIMINARY TITLE REPORT EXCEPTION NUMBER PLOTTED HEREON.

### PROJECT NOTES

PROJECT CONSISTS OF 2 MASTER LOTS AND 19 AIR SPACE LOTS.

THOMAS BROTHERS GUIDE: PAGE 563 - GRID C4

CADASTRAL MAP: 166B181

PROPOSED UTILITIES: SEWAGE AND DRAINAGE WILL BE PROVIDED BY THE CITY OF BURBANK INFRASTRUCTURE SYSTEMS. THE SITE SHALL TIE INTO EXISTING SEWER INFRASTRUCTURE.

LOT CONFIGURATIONS AND SIZES ARE APPROXIMATE IN NATURE AND WILL BE FINALIZED DURING THE FINAL MAP PHASE.

WE RESERVE THE RIGHT TO CONSOLIDATE LOTS.

PROPOSED RECIPROCAL INGRESS/EGRESS EASEMENTS (IF ANY) ARE YET TO BE DETERMINED.

THE SITE DOES NOT CONTAIN ANY PROTECTED TREES. ALL TREES ARE TO BE REMOVED.

WE RESERVE THE RIGHT TO PHASE THE FINAL MAP.

WE PROPOSE SUBTERRANEAN ENCROACHMENT EASEMENT FOR LEVEL B2 & B3 ALONG ALLEY.

WE PROPOSE ENCROACHMENT EASEMENT FOR BRIDGE 16.83' ABOVE THE GROUND AT ALLEY.

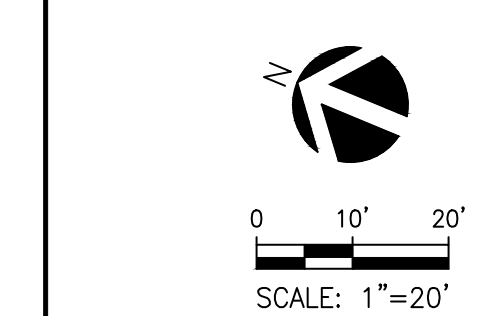
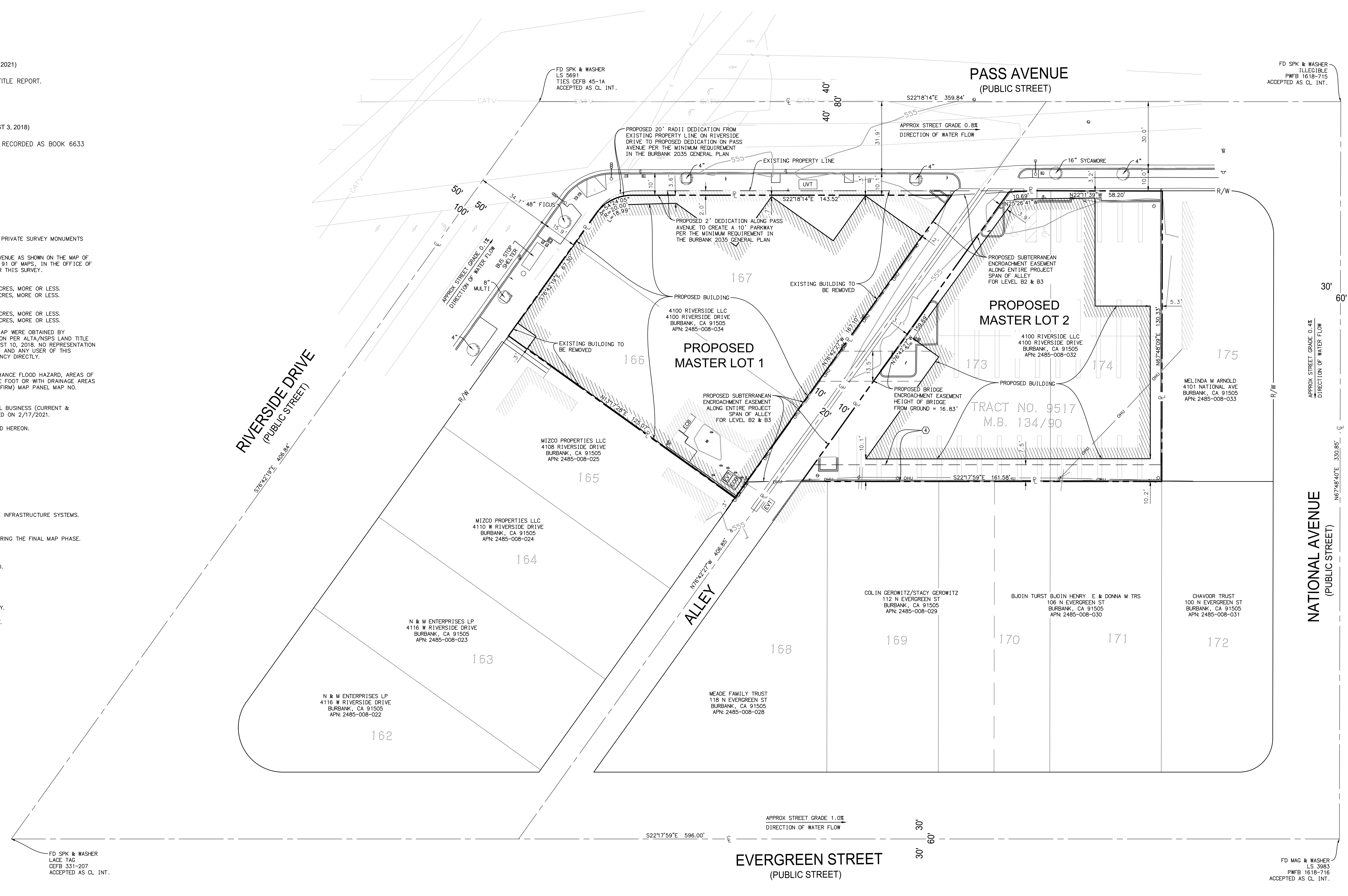

REVISIONS	
DATE	ISSUED FOR

DATE	07/06/2022
PROJECT NUMBER	2000545
DRAWN BY	NL
CHECKED BY	CJ
SCALE	AS SPECIFIED

PROJECT DESCRIPTION  
4100 RIVERSIDE DRIVE  
BURBANK, CA 91505  
VESTING TENTATIVE TRACT MAP NO. 83858

SHEET NUMBER

PREPARED UNDER THE DIRECTION OF:  
*C.J.*  
CHRISTOPHER M. JONES  
CHRIS.JONES@KPFF.COM  
07/06/2022

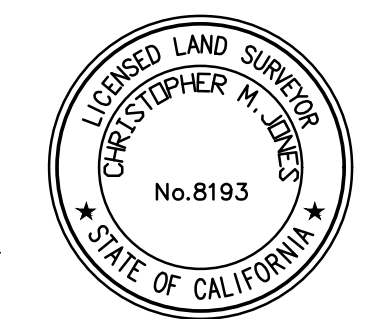

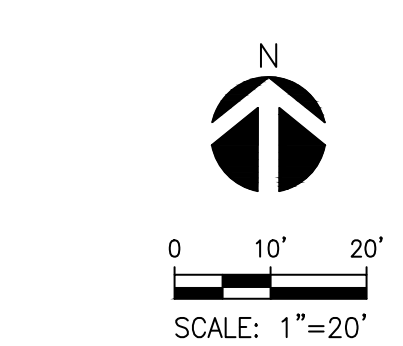
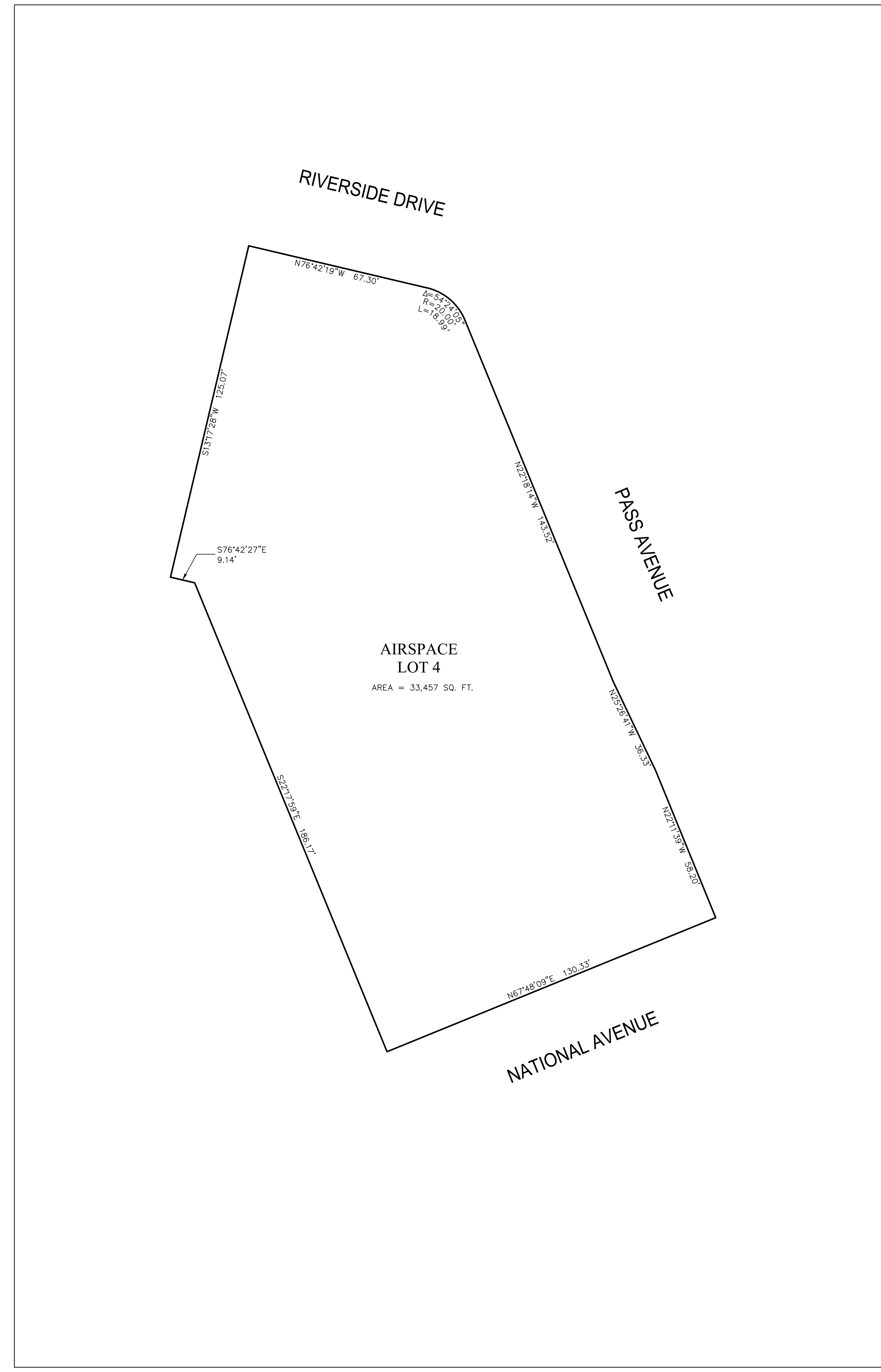
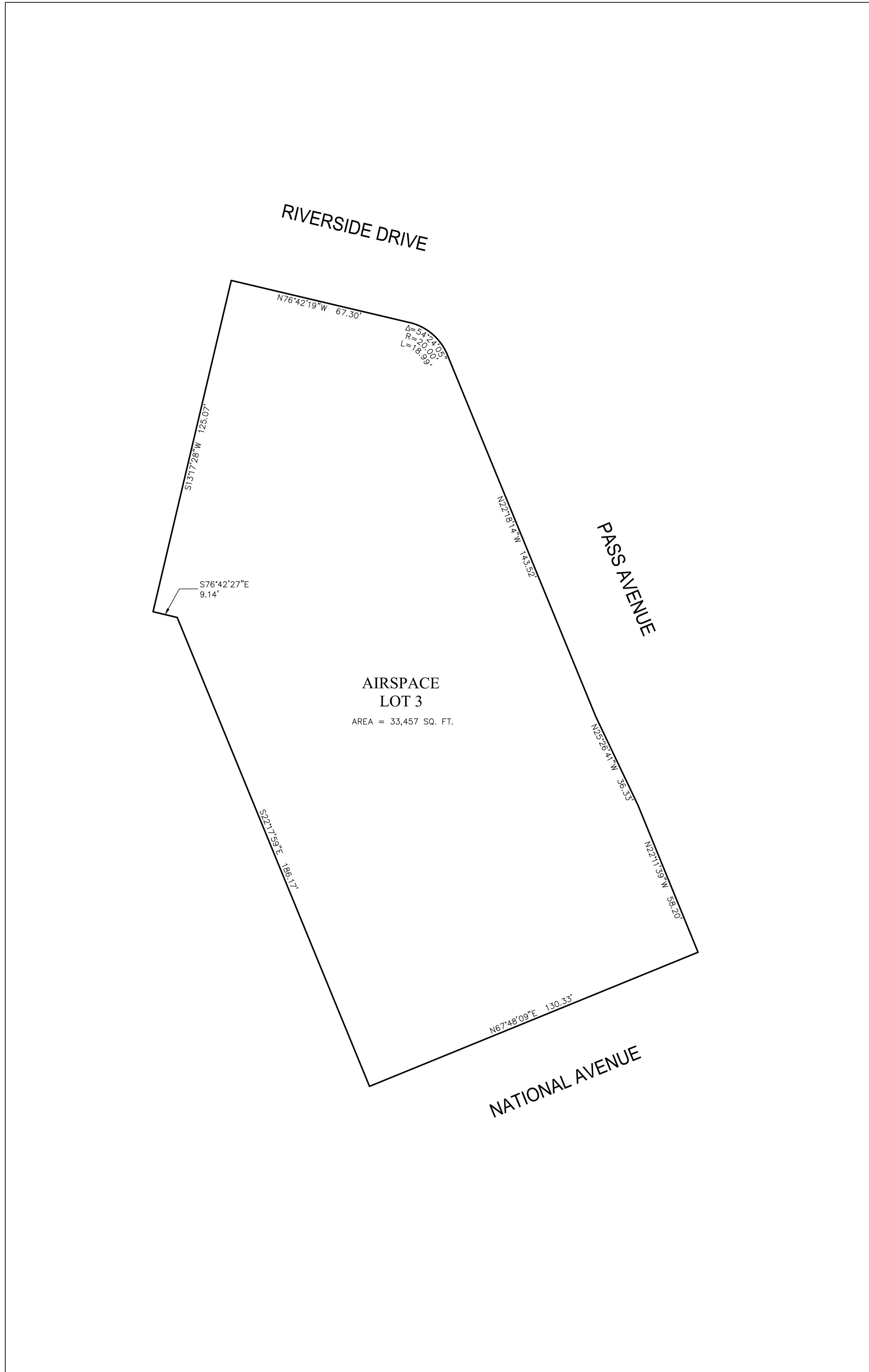

REVISIONS	
DATE	ISSUED FOR

DATE	06/07/2022
PROJECT NUMBER	2000545
DRAWN BY	NL
CHECKED BY	CJ
SCALE	AS SPECIFIED

PROJECT DESCRIPTION  
 4100 RIVERSIDE DRIVE  
 BURBANK, CA 91505  
 VESTING TENTATIVE TRACT MAP NO. 83858

SHEET NUMBER

L.E. = LOWER ELEVATION  
 U.E. = UPPER ELEVATION



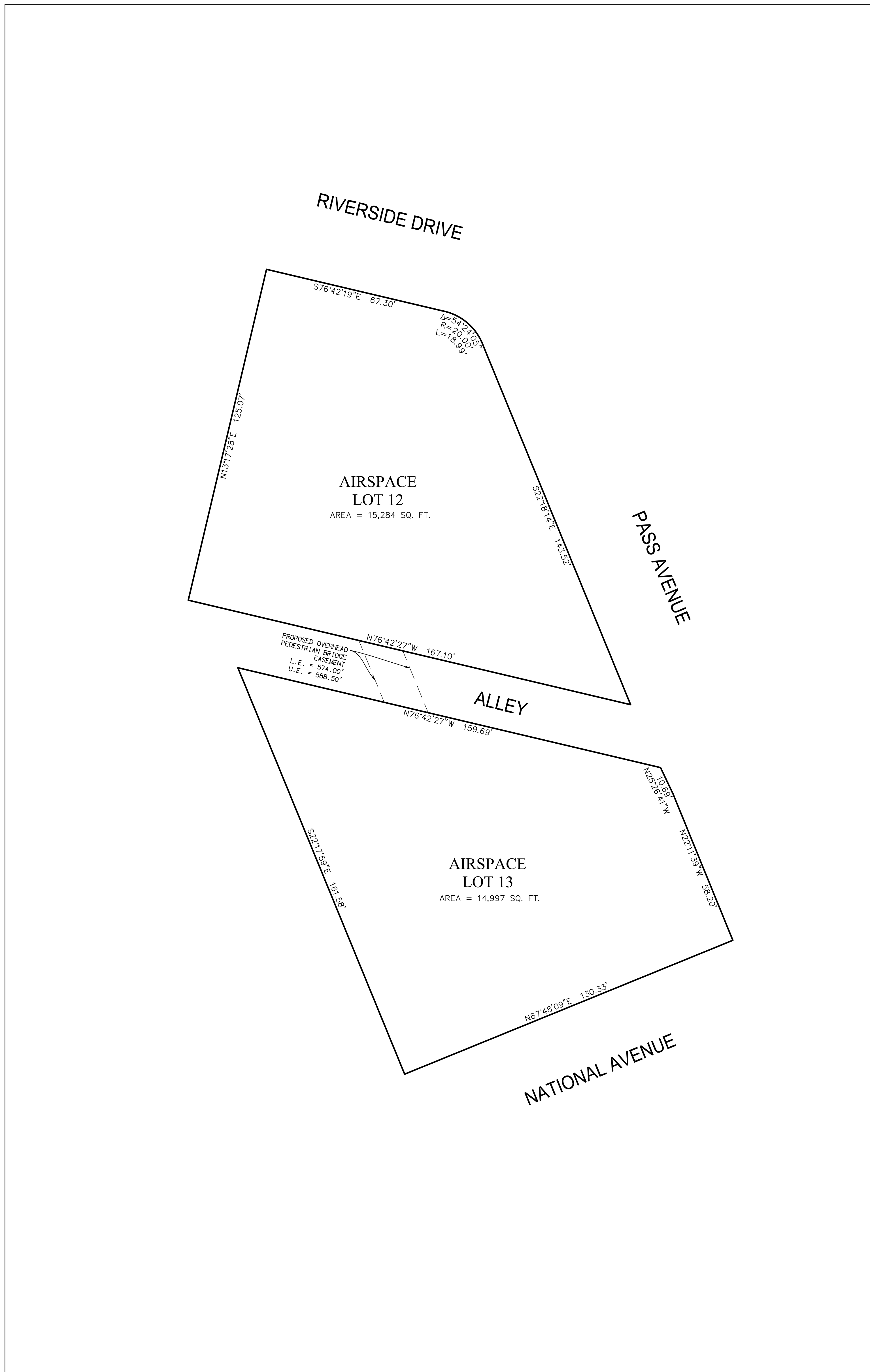

LEVEL 02  
 L.E. = 574.00', U.E. = 585.00'

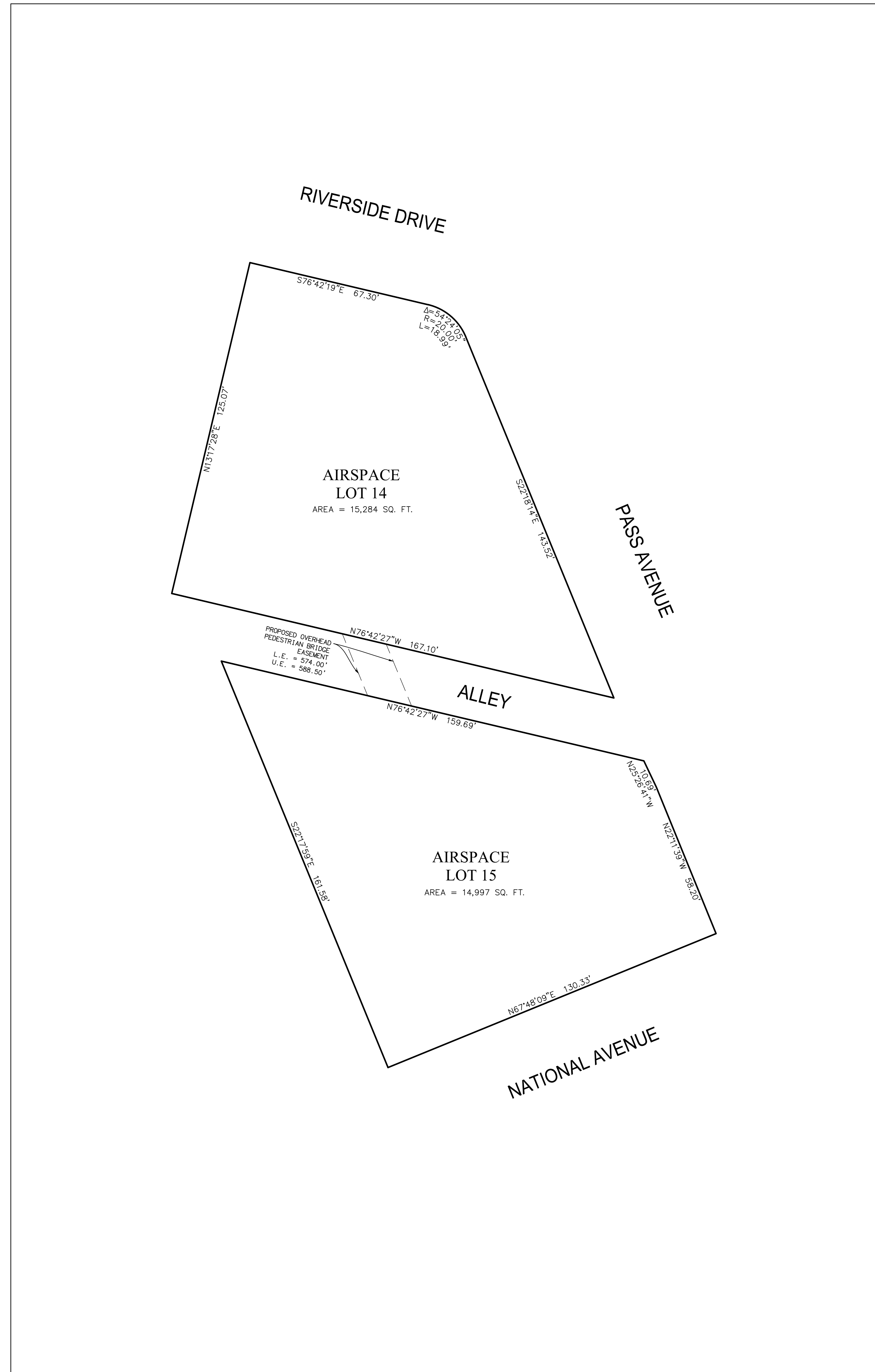

LEVEL 03  
 L.E. = 585.00', U.E. = 598.00'

L.E. = LOWER ELEVATION  
 U.E. = UPPER ELEVATION

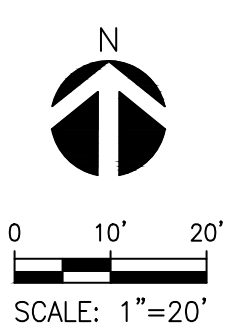

REVISIONS	
DATE	ISSUED FOR

DATE	06/07/2022
PROJECT NUMBER	2000545
DRAWN BY	NL
CHECKED BY	CJ
SCALE	AS SPECIFIED

PROJECT DESCRIPTION  
 4100 RIVERSIDE DRIVE  
 BURBANK, CA 91505  
 VESTING TENTATIVE TRACT MAP NO. 83858

SHEET NUMBER

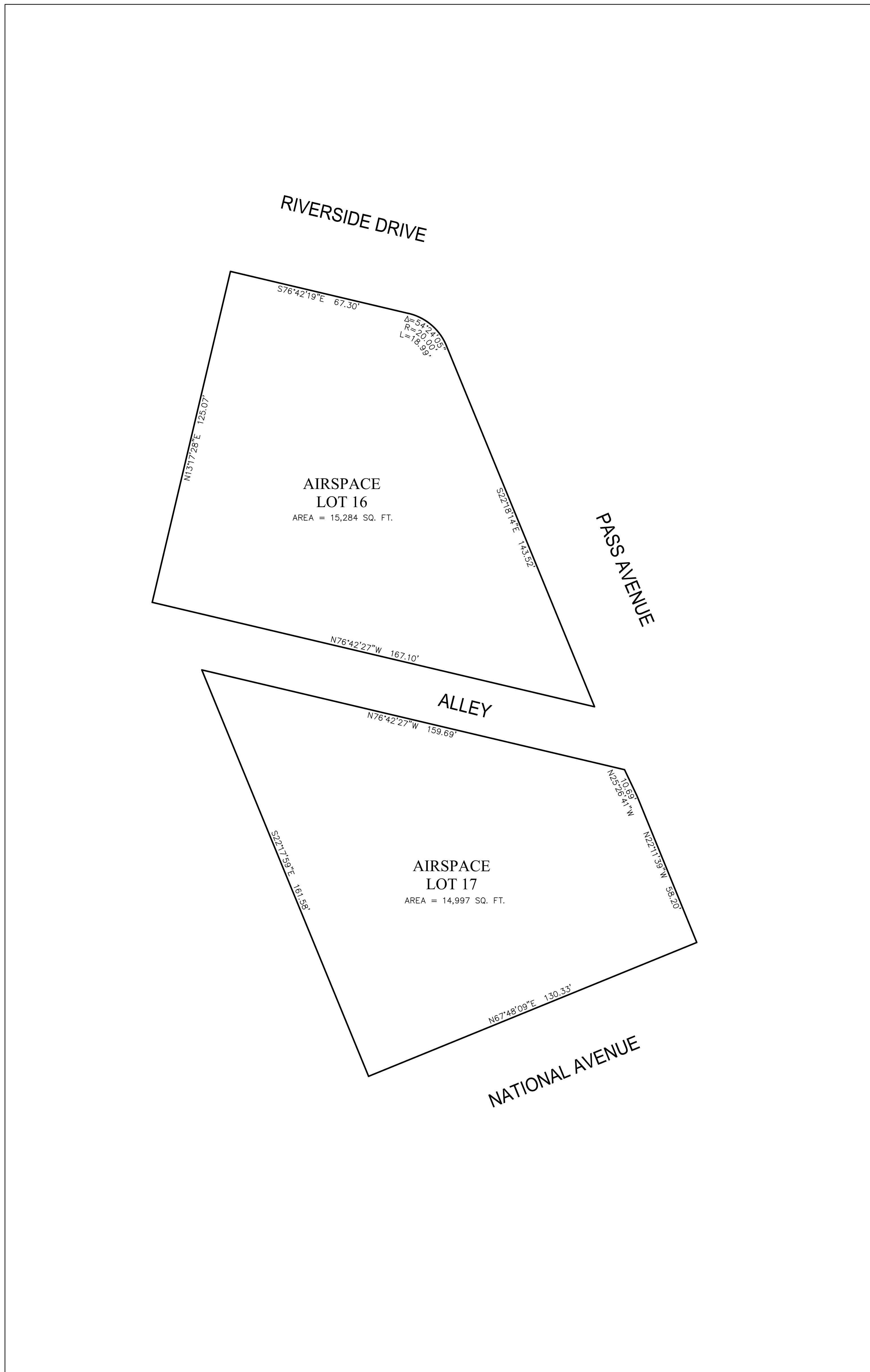

LEVEL 04  
 L.E. = 596.00', U.E. = 607.00'

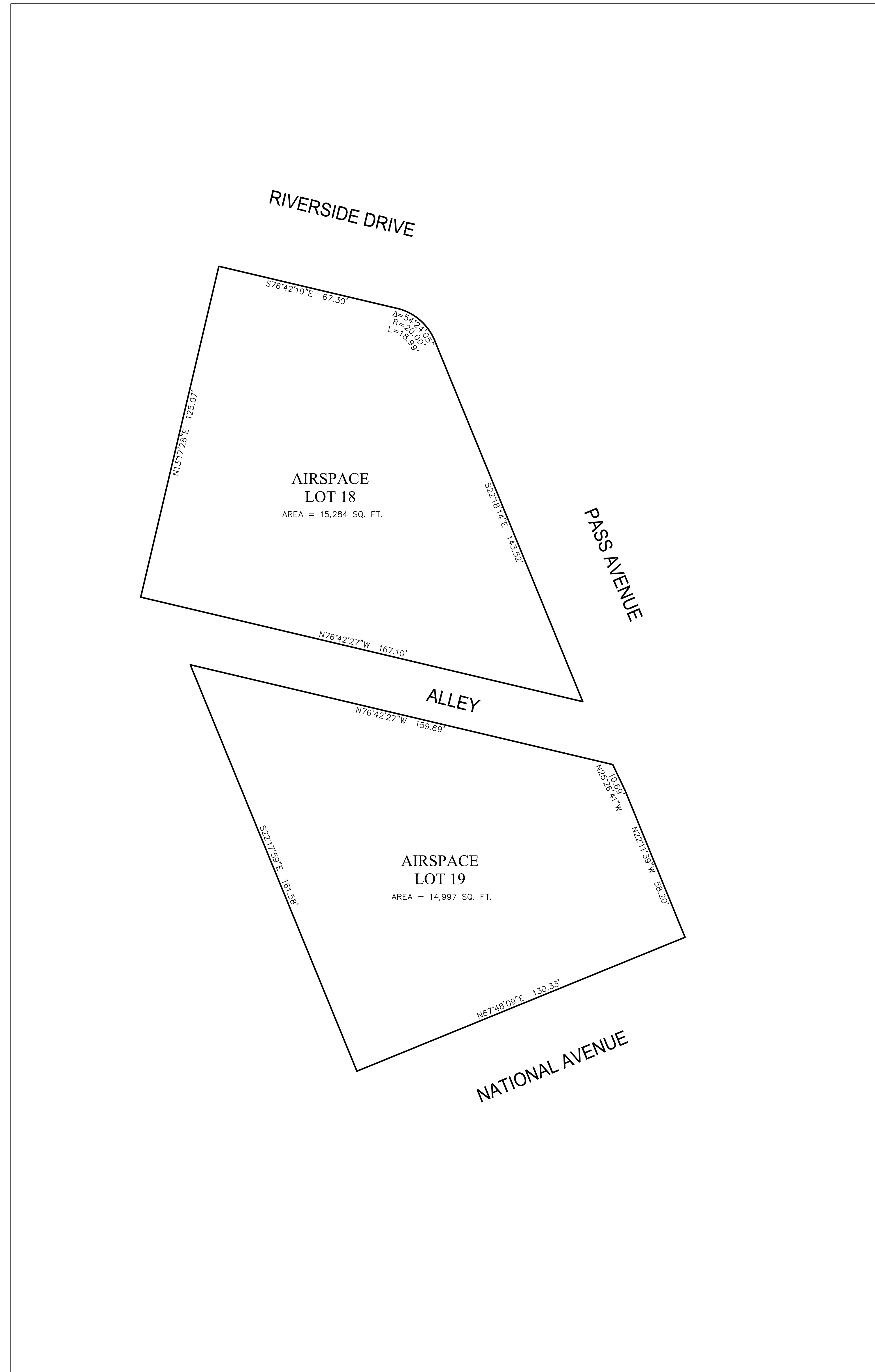

LEVEL 05  
 L.E. = 607.00', U.E. = 618.00'

L.E. = LOWER ELEVATION  
 U.E. = UPPER ELEVATION

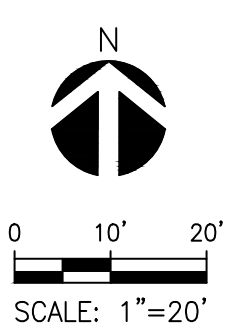

REVISIONS	
DATE	ISSUED FOR

DATE	06/07/2022
PROJECT NUMBER	2000545
DRAWN BY	NL
CHECKED BY	CJ
SCALE	AS SPECIFIED

PROJECT DESCRIPTION  
 4100 RIVERSIDE DRIVE  
 BURBANK, CA 91505  
 VESTING TENTATIVE TRACT MAP NO. 83858

SHEET NUMBER

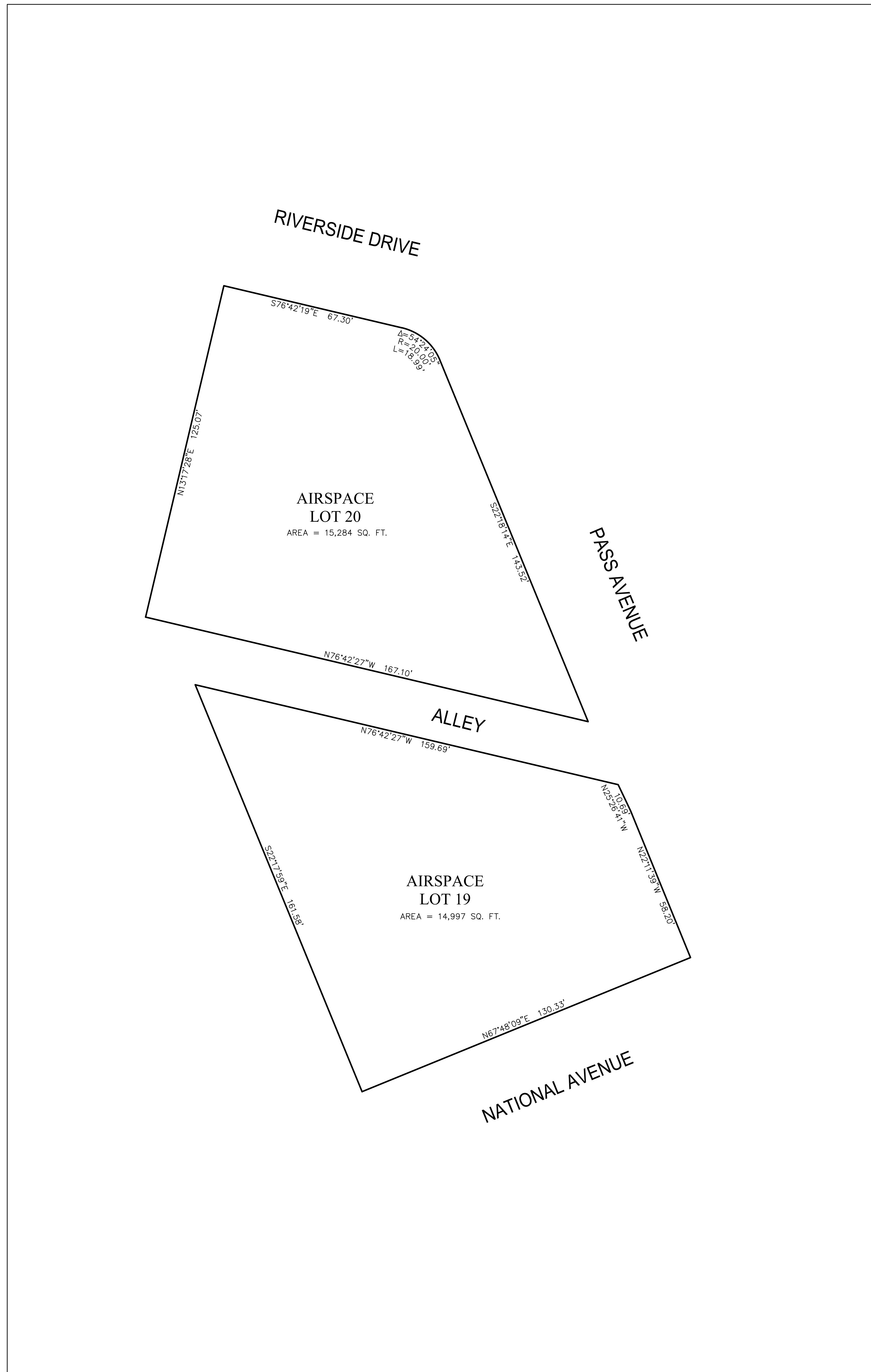

LEVEL 06  
 L.E. = 618.00', U.E. = 629.00'

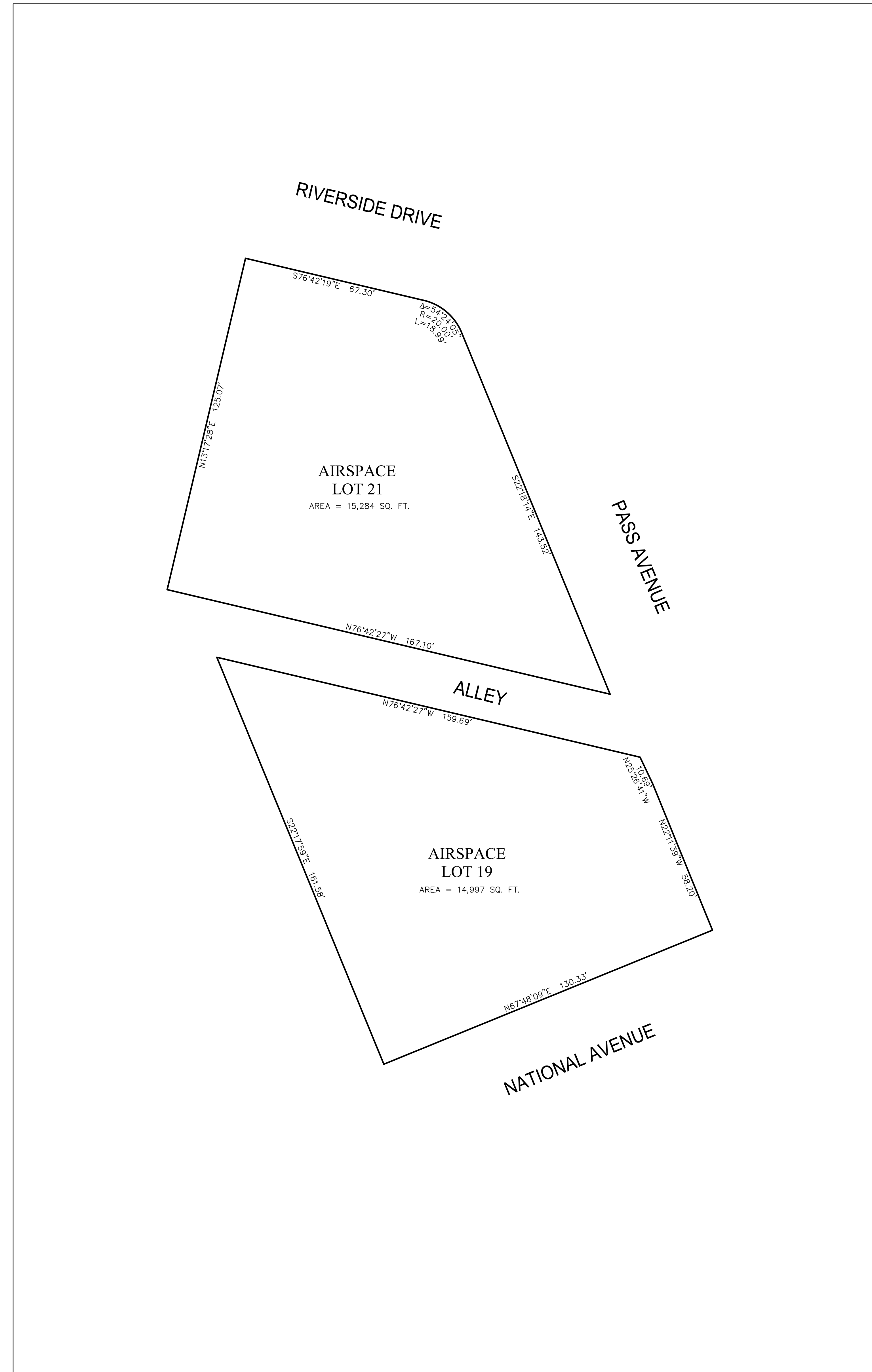

LEVEL 07  
 L.E. = 629.00', U.E. = TO THE HEAVENS

L.E. = LOWER ELEVATION  
 U.E. = UPPER ELEVATION

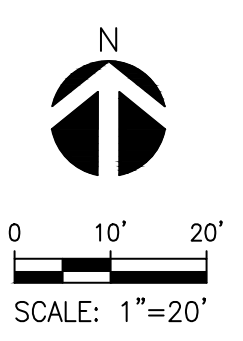

REVISIONS	
DATE	ISSUED FOR

DATE	06/07/2022
PROJECT NUMBER	2000545
DRAWN BY	NL
CHECKED BY	CJ
SCALE	AS SPECIFIED

PROJECT DESCRIPTION  
 4100 RIVERSIDE DRIVE  
 BURBANK, CA 91505  
 VESTING TENTATIVE TRACT MAP NO. 83858

SHEET NUMBER

