

TENTATIVE TRACT MAP NO. 84031

IN THE CITY OF BURBANK, STATE OF CALIFORNIA
FOR NEW CONDOMINIUM PURPOSES

DATE: OCTOBER 24, 2023

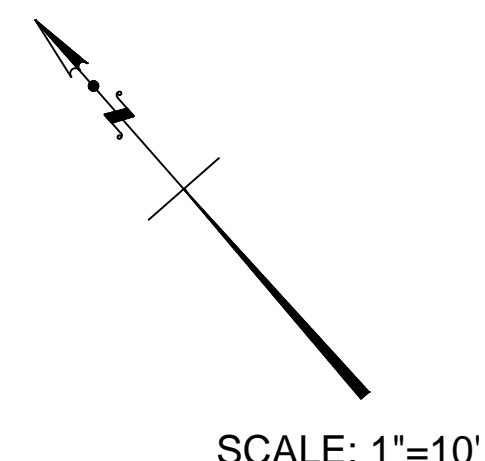
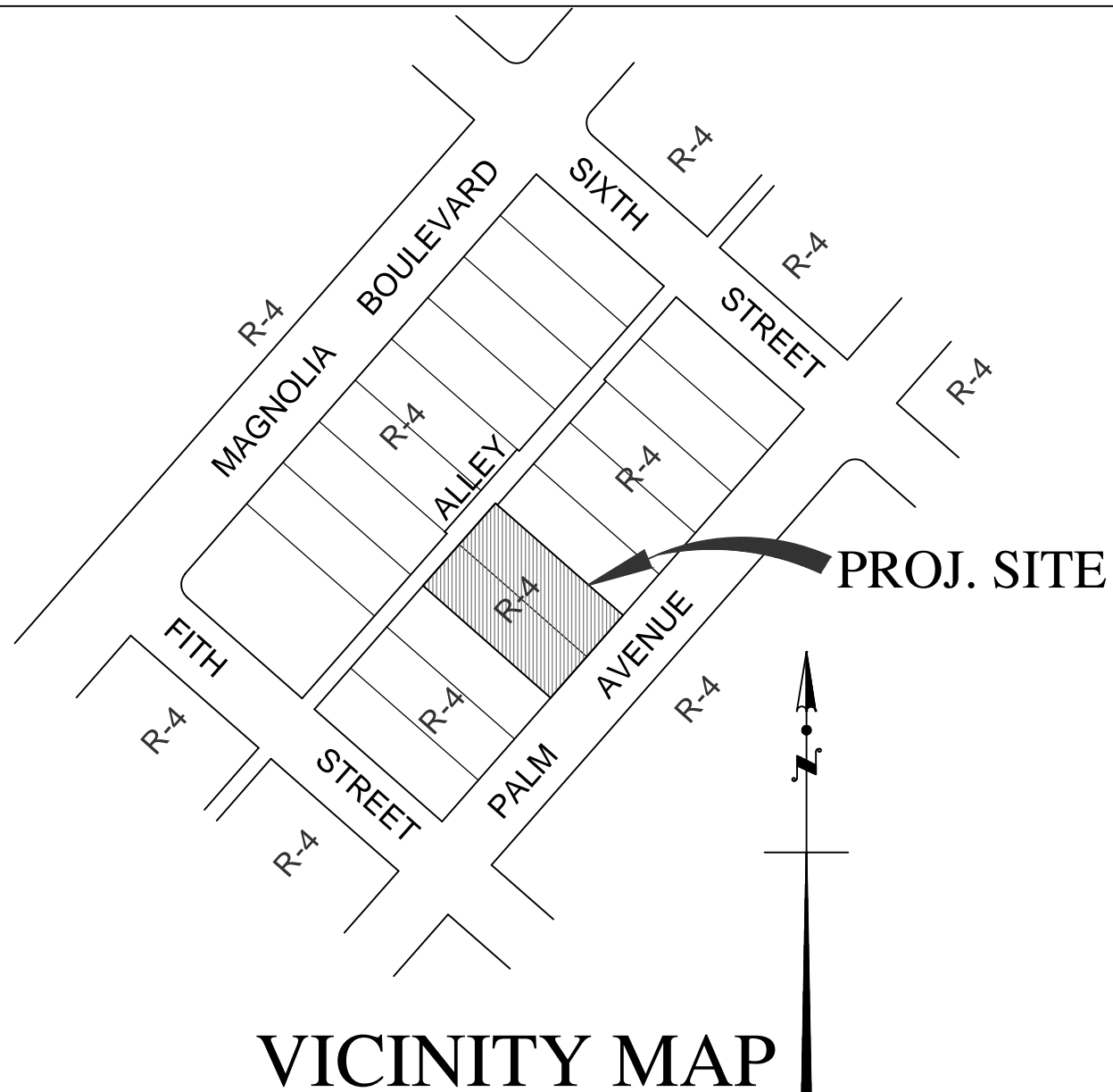

OWNER / SUBDIVIDER

PALM TOWNHOMES LLC
530 S. GLENOAKS BLVD. STE. 200
BURBANK, CA 91502
TEL: (818) 266-9277

ENGINEER

TECHNA LAND CO.
HAYK MARTIROSIAN
1545 N. VERDUGO RD. SUITE 2
GLENDALE, CA 91208
TEL: (818) 547-0543
RCE 52563

PROJECT ADDRESS

529 AND 537 E. PALM AVENUE
BURBANK, CA 91501

LEGAL DESCRIPTION

LOTS 11 AND 13 IN BLOCK 35 OF TOWN OF BURBANK TRACT,
M.R. 17, PAGES 19-22

PROJECT DATA

EXIST. ZONE: ----- R-4
 GENERAL PLAN: ----- HIGH DENSITY RESIDENTIAL
 EXIST. USE: ----- 1 SINGLE FAMILY DWELLING UNIT+ 2 DUPLEX UNITS +
 1 DETACHED STRUCTURE+1 DETACHED GARAGE
 PROP. USE: ----- 24- UNITS CONDOMINIUM BUILDING
 16 UNITS BY RIGHT+8 UNITS STATE DENSITY BONUS
 NO. OF STORIES: ----- 4 OVER 2 LEVEL OF SUBTERRANEAN PARKING
 PROVIDED PARKING: ----- 38 (31 STANDARD + 6 GUEST + 1 ACCESSIBLE PARKING)
 PROV'D. PVT. OPEN SPACE: ----- 2247 SQ. FT.
 PROV'D. COMMON OPEN SPACE: ----- 3780 SQ. FT.
 LOT AREA BEFORE DEDICATION: ----- 15,516.85 SQ. FT., 0.356 AC
 (WITHIN EX. BOUNDARIES)
 LOT AREA AFTER DEDICATION: ----- 15,267.17 SQ. FT., 0.351 AC.
 ASSESSOR PARCEL NO. ----- 2455-030-011, 2455-030-013

EASEMENT:

NONE
 PER CHICAGO TITLE CO., POLICY NO. CA-FLAC-IMP-72067-1-19-00587741
 ORDER NO. 00587741-989-LAB-BLA, DATED APRIL 26, 2019, APN:2455-030-013
 PER STEWART TITLE CO., POLICY NO. O-0000291307888
 DATED: NOV. 30, 2018, APN: 2455-030-011

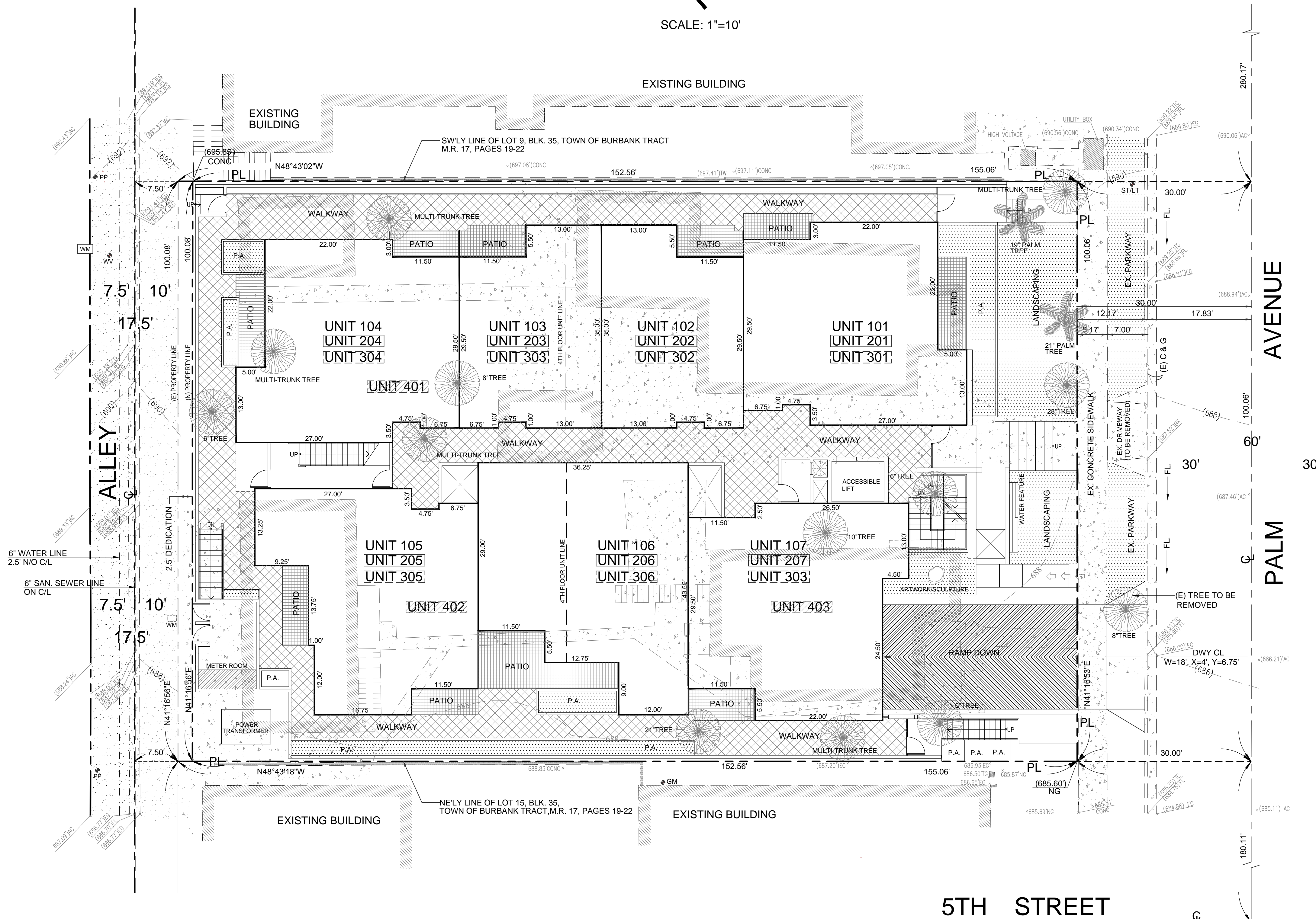

LEGEND

- UNIT 101 — FIRST FLOOR UNIT
- UNIT 201 — SECOND FLOOR UNIT
- UNIT 301 — THIRD FLOOR UNIT
- UNIT 401 — FOURTH FLOOR UNIT

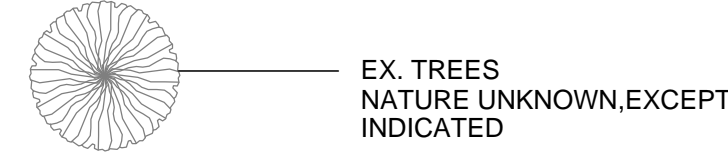

TENT.TR. NO. 84031

TECHNA LAND CO. INC.
CIVIL ENGINEERING, LAND PLANNING, CONST. MGMT.



Hayk Martirosian 10-24-23
 HAYK MARTIROSIAN DATE
 1545 N. VERDUGO RD. # 2 GLENDALE, CA 91208
 TEL: (818) 547-0543, FAX: (818) 547-1074